

The LS300 3-bottle trough provides a continuous supply of liquor, wine, or mixers to your Smartender system. Designed for medium and high-volume applications, the LS300 allows the delivery of three bottles sequentially to the Smartender unit before refill, thereby eliminating bottle changes during high volume hours.

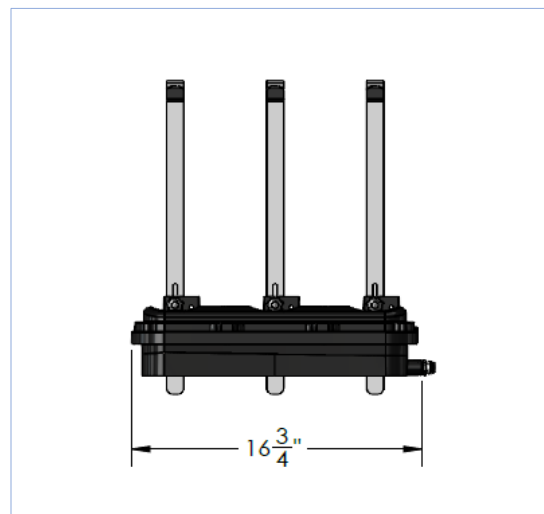
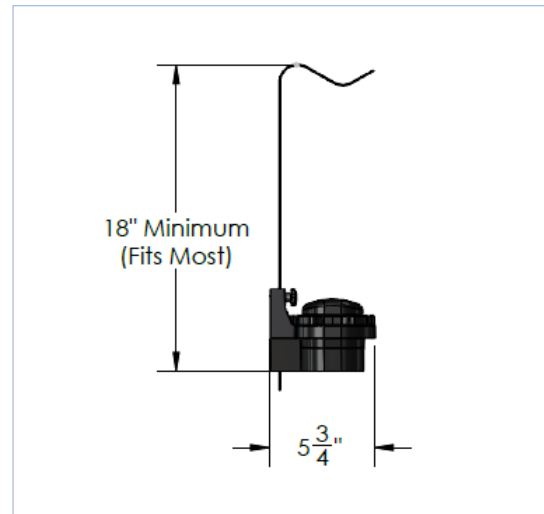
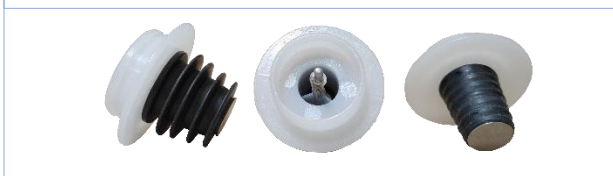

### Features and Benefits

Spill resistant bottle caps for easy bottle replacement.

Accommodates bottles up to 1.75 Liters

Flexibility for wire rack or wall mounting.

Sequential bottle emptying from front to back.

### Technical Specifications

Liquor Capacity	1 brand, 3 bottles per
Safety	ETL Sanitation
Material	Polymeric
Weight	3 Pounds (each, no product)



1(866)399-7160

CONTACT@SMARTBARUSA.COM

WWW.SMARTBARUSA.COM

US & Foreign Patents & Patent Pending Nos.: US8584900, US8651333, US8746507, US9371219, US9776848, US9652756, GB2483129, JP5878467, J/001782, ZL201080003573.X, MX332670, HK1181739, AT2582616, BE2582616, CH2582616, DK2582616, FR2582616, GB2582616, IT2582616, NL2582616, CA2803146, JP5863787, EP2582616, ES2554501, SE11798752.9, AU2011271145, SG186263, IN00569/DELNP/13, BR112012032780-1, ZL201180030544.7, DE602011021248.6, MX336235, CA2803148, JP6049018, J/002046, EP2582617, HK13109236.0, AU2011271058, SG186265, IN000329/DELNP/13, BR112012032751-8, ZL201180030469.4, J/002279